

**Disassembly and pressure discharge of STABILUS products prior to disposal**

The print-out is not subject to the modification service.

2.4 Model : BLOC-O-LIFT

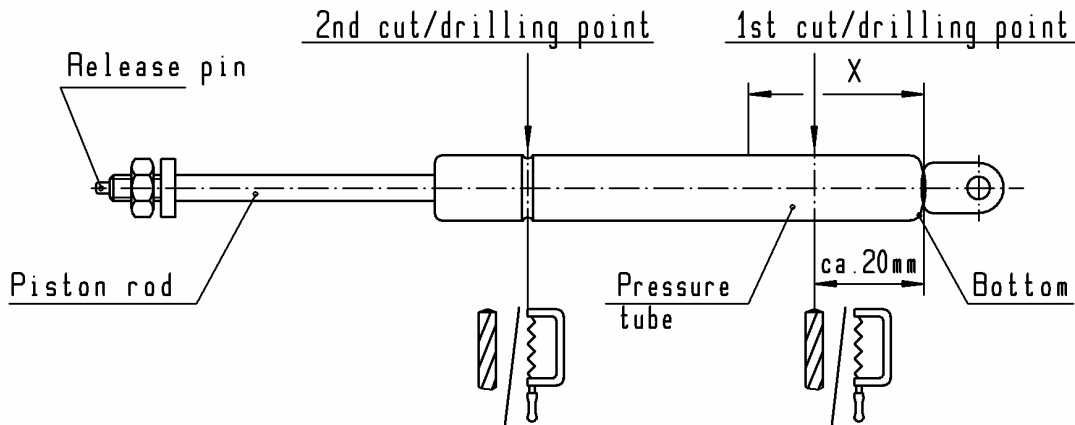

First saw cut/drilling point : Saw or drill the pressure tube open about 20 mm from bottom.

Second saw cut/drilling point : Saw or drill the pressure tube open in the groove.

Intended for internal and external use

EN

DE: X | EN: X | ES: X | IT: X | PR: X | FR: X  
Preceding edition: 11.11.1993

Rev.: 10