



## INDUSTRIAL POWERISE® IPR35

The new class of electromechanical drives

DATA SHEET

LIFTING AND POSITIONING  
AT THE PUSH OF A BUTTON



STABILUS

STABILUS

Verkehrshof  
Stabilus

# PRODUCTS

## A FAMILY WITH POWER

### The combination makes the difference

Every industrial application is different. Industrial POWERISE® offers a range of options even in the standard variants: This includes different combinations including of spindle pitch, force, stroke and speed, external or internal control units and/ or graduated communication options up to a CAN bus interface. Even with much configuration freedom, streamlined dimensions allow for ergonomic product design.

#### You have a choice:

- From the factory by ACE
- Adjustment via Hahn Gasfedern
- Custom development with Stabilus



#### IPR35

- External controller
- Ideal for moderate forces up to 2.5 kN
- Standard products for different applications and configurations

### See what's coming next



#### IPR35 SMART

- Integrated control
- Synchronous operation of up to four drives
- Simple activation

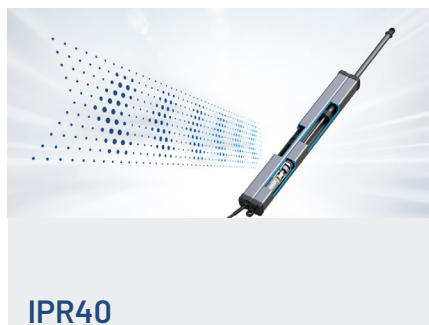

#### IPR40

- Built-in limit switch
- Active and passive forces up to 5 kN
- Various connection options



#### IPR40 SMART

- Internal control
- Safety according to EN ISO 13849-1
- CAN bus communication

# INDUSTRIAL POWERISE®

## POWER MEETS CONTROL

Industrial POWERISE® is the new class of electromechanical drives for elegant, precise, and powerful motion control. They deliver safety, comfort, and protection while facilitating maintenance in a wide variety of applications.

### PROVEN FEATURES AND UNIQUE SYSTEM RANGE

You will also benefit from proven features like **maintenance-free** performance or convenient **manual adjustment**, in addition to electrical movement. **Combined with** our globally leading **gas springs**, Industrial POWERISE® offers a system range that's unique within the industry.



#### APPLICATION ENGINEERING

Partnership to develop exactly the right solution for your requirements



#### ACTUATOR PLUS GAS SPRINGS

Unique combination of dynamic force and load compensation

- Faster movement
- Higher weights possible
- Smoother manual movement



#### AVAILABLE FROM STOCK

Get the maintenance-free Industrial POWERISE® drives within short notice



#### SILENT MOVEMENT

Best-in-class noise performance for sensitive environments



#### INTEGRATED CONTROL

Integration of the ECU (electronic control unit) in the drive (for SMART models)



#### SAFETY INTEGRATED

Safe control according to EN ISO 13849-1 (for IPR40 Smart and the external ECU)



#### AUTOMOTIVE DNA

Stabilus is the OEM no. 1 in the industry with the IATF certified drive of the Automotive POWERISE®



#### MODULAR SYSTEM

Custom configuration and simple adjustment on a modular basis

# TECHNOLOGY

## 100% "INDUSTRIAL"

POWERISE® drives are available with spindle pitches between 2 and 25 mm. That means they open up all new application approaches with minimal manual adjustment force and comfortable function – even without power. Industrial POWERISE® remains ready to use, even where drives with a self-locking feature can no longer be moved, or require complicated uncoupling.

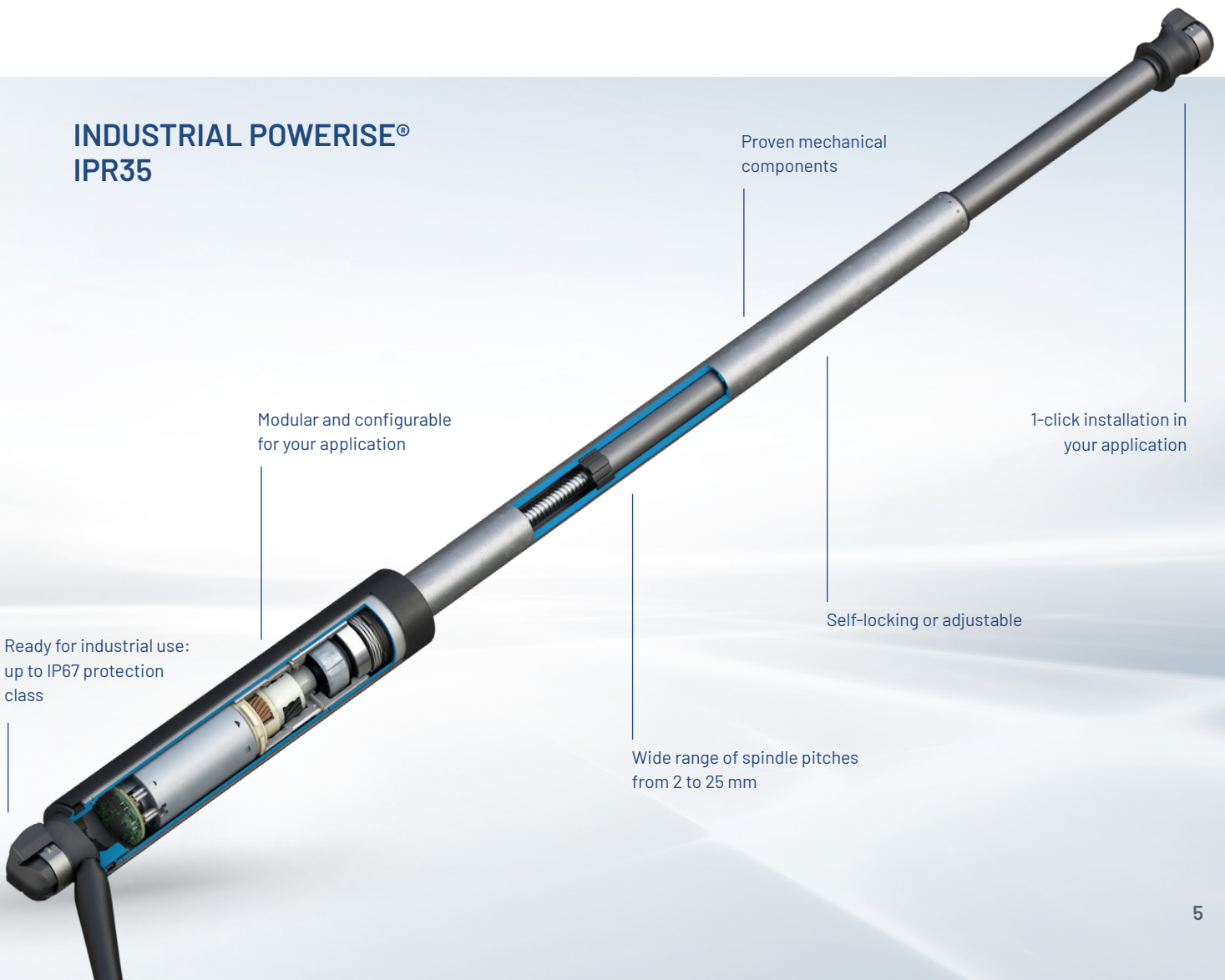

### INDUSTRIAL POWERISE® IPR35

Ready for industrial use:  
up to IP67 protection  
class

Modular and configurable  
for your application

Proven mechanical  
components

1-click installation in  
your application

Self-locking or adjustable

Wide range of spindle pitches  
from 2 to 25 mm

# GENERAL SPECIFICATIONS

## MAIN FACTS AND FIGURES OF THE SYSTEM

### Technical data

**Operating voltage:** 12 V or 24 V

**Rated force range:** 250 - 1,000 N

**Peak force range:** 1,000 - 4,000 N\*

**Stroke range:** 50 - 350 mm; standard in 50 mm increments

**Noise level:** 55 dB (A), for general applications; exact result is installation-dependent

**Duty cycle:** Max 10%, 20 sec on, 180 sec off

**Lifetime cycles:** Min. 50.000, application- and load-dependent based on operating point

### Environmental conditions

**Operating temperature:** -30 °C to +80 °C

**Storage temperature:** -40 °C to +90 °C

**Ingress protection class:** Up to IP67, IEC 60529

**Corrosion resistance:** 144 hours, ISO 9227-NSS

**UV Resistance:** DIN EN ISO 16474-2

**Vibration Resistance:** DIN EN 60068-2-64

**Shock Resistance:** DIN EN 60068-2-27

**Regulatory standards:** EN 60204-1:2018 Safety - Electrical equipment of machines

EN 60335-1:2012 Safety - Household and similar electrical appliances

EN IEC 55014-1:2021 EMC Emission - Household appliances, electric tools and similar apparatus

EN IEC 61000-6-3:2021 EMC Emission - Residential environments

FCC Part 15 B / IECS-003 EMC Emission

### Motor variants

	12 V Motor	24 V Motor
Maximum voltage	16 V	30 V
Peak current (Inrush or momentary use <2sec)	25.2 A	9.7 A
Nominal operating current	7 A	3.5 A

### Cable bending radius

**Static bend:** 37.5 mm (1.5 in)

**Continuous bending:** 112.5 mm (4.4 in)

\*on request

# ADDITIONAL TECHNICAL DATA

## THERMAL PROTECTION FOR MOTOR

With the bimetallic circuit breaker, you can be sure that your Industrial POWERISE® drive will not be exposed to thermal overload.

Thermal protection is crucial for the safe function and longevity of your components.

### Conditions

**Motor thermal protection:** Automatic power cutoff via integrated thermal Switch - Motor function is blocked

**Protection activation:** 120 °C (248 °F)

### Dimensions

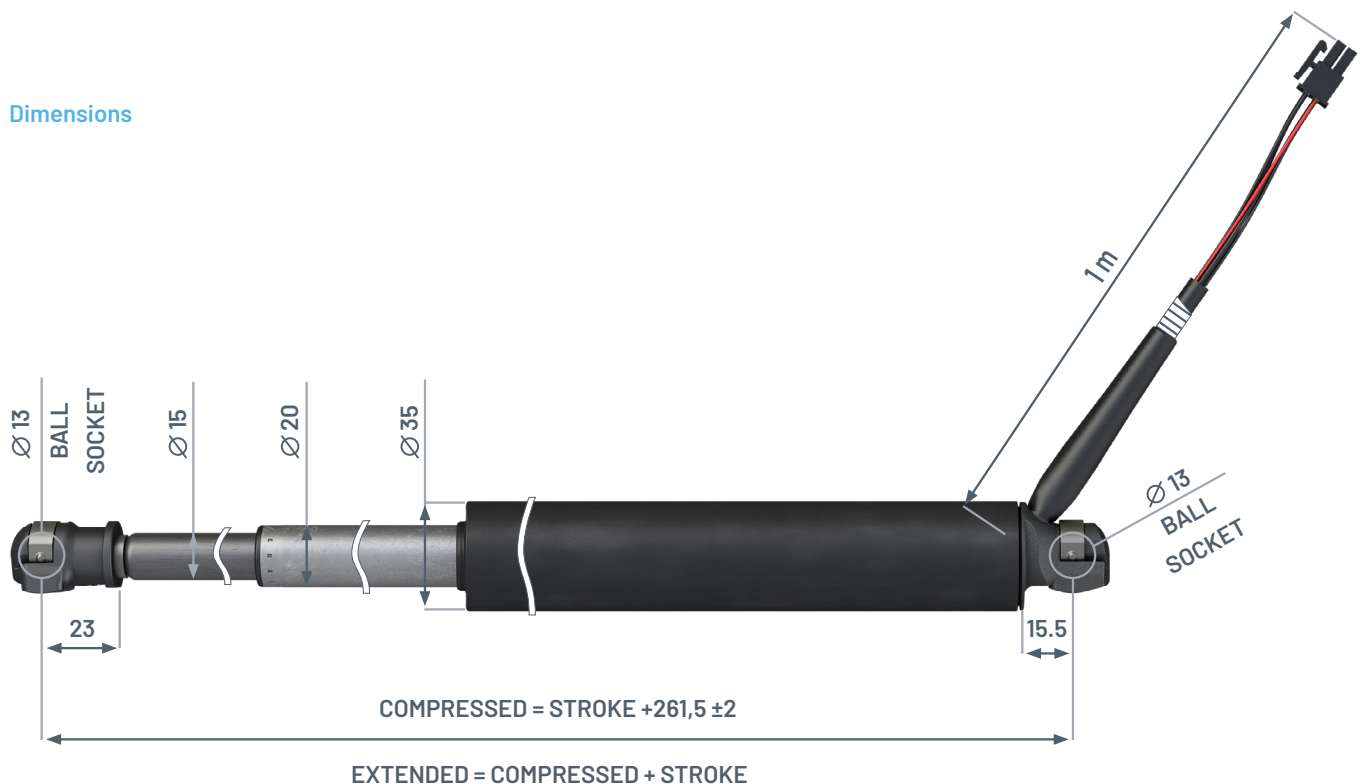

# TYPE OVERVIEW

## ONE PRODUCT, VARIOUS APPLICATIONS

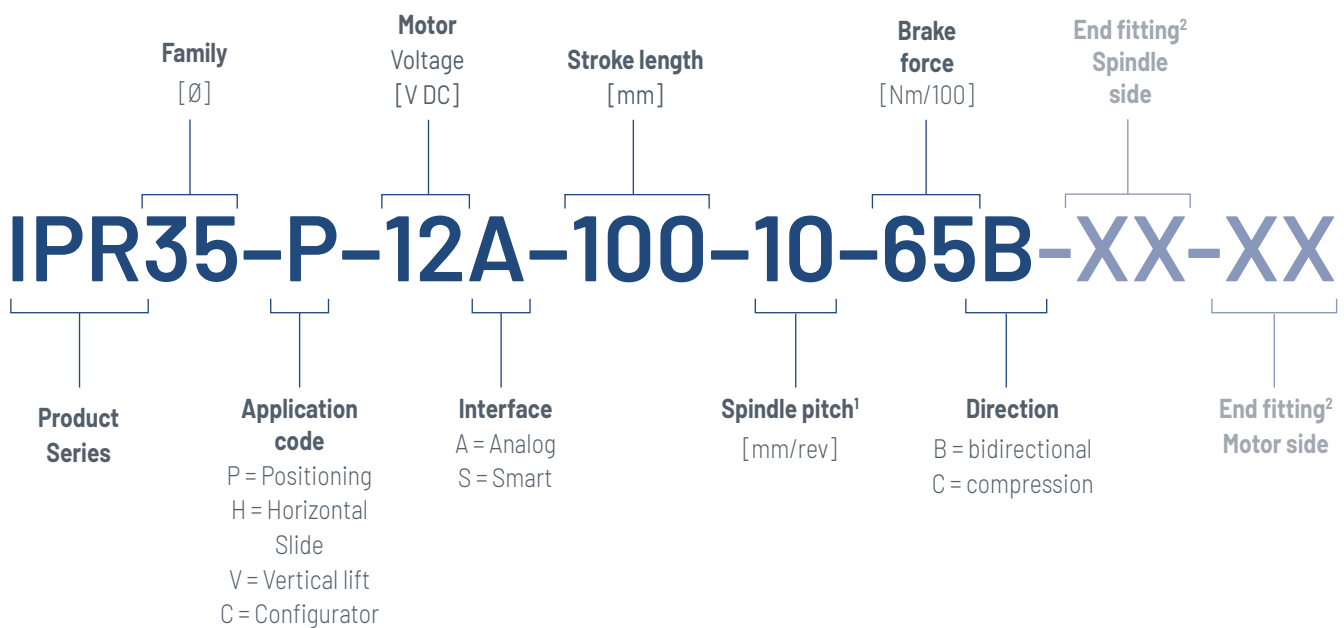

<sup>1</sup> Further spindle pitches on request  
<sup>2</sup> not relevant for IPR35



### Description of vertical lift

- Application examples: Hoods and roofs
- Specialized for holding high compression loads and easy manual movement in extension
- Designed with compression brake only



### Description of horizontal slide

- Application examples: Doors and entryways
- Low holding force for easy manual movement in either direction
- Designed with high spindle pitches, light brakes



### Description of positioning system

- Applications examples: Traditional linear actuators, general purpose
- High holding force in both directions, containing a dual-action friction brake
- Designed with strong brake in both directions

# COMBINATION WITH GAS SPRINGS

## DYNAMIC FORCE MEETS LOAD COMPENSATION

Industrial POWERISE® delivers the dynamic force – the gas springs add load compensation. This provides you and your application with uniquely ergonomic, force- and energy-saving and safe movement and operation – even in an emergency like a power outage. Generally, you can move objects faster while gently applying manual force. This combination opens the door to new applications that you can use to stand out from the competition.

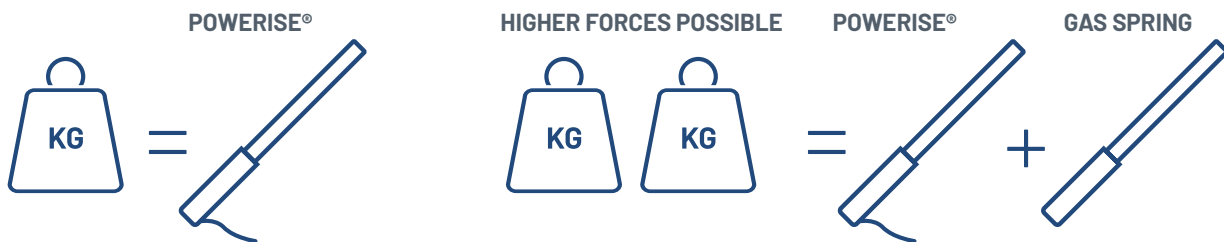

One Industrial POWERISE® drive can be combined with different gas springs to suit a range of application sizes. The drive configuration stays identical.

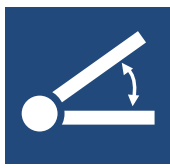

# TECHNICAL DATA

## VERTICAL LIFT

### PERFORMANCE DATA

For vertical lift [V]

TYPES	Spindle pitch mm/rev	Motor Voltage V DC	No load speed mm/s	Rated			Peak <sup>1</sup>		Holding force	
				pushing force N	pulling force N	speed mm/s	force, push N	force, pull N	extension N	compression N
IPR35-V-12A-XXX-15-65C	15	12	85	390	210	70	1,100	1,050	120	390
IPR35-V-24A-XXX-15-65C	15	24	85	450	280	57	1,050	950	120	390
IPR35-V-12A-XXX-8-65C	8	12	35	750	420	28	2,000	1,700	220	760
IPR35-V-24A-XXX-8-65C	8	24	35	880	550	23	1,900	1,600	220	760

<sup>1</sup>Recommended no more than 2 s

### Individual part numbers

TYPES	Stroke / Extended length						
	50 / 361.5 mm	100 / 461.5 mm	150 / 561.5 mm	200 / 661.5 mm	250 / 761.5 mm	300 / 861.5 mm	350 / 961.5 mm
IPR35-V-12A-XXX-15-65C	709410	709171	425953	602332	425714	425475	426192
IPR35-V-24A-XXX-15-65C	706064	705347	720162	187189	720401	720640	720879
IPR35-V-12A-XXX-8-65C	709649	709888	372895	606156	372417	373612	374807
IPR35-V-24A-XXX-8-65C	706303	705825	921160	188384	721357	721596	721118

### PERFORMANCE DIAGRAMS

Vertical lift – force/speed ratio

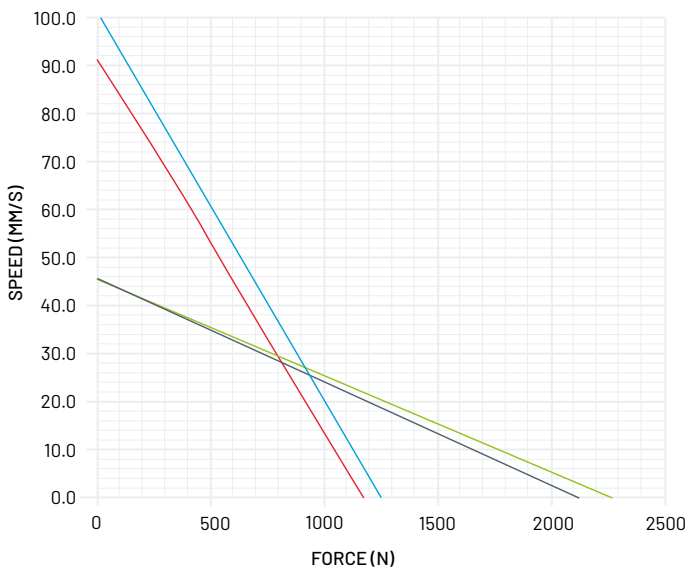

Vertical lift – force/current ratio

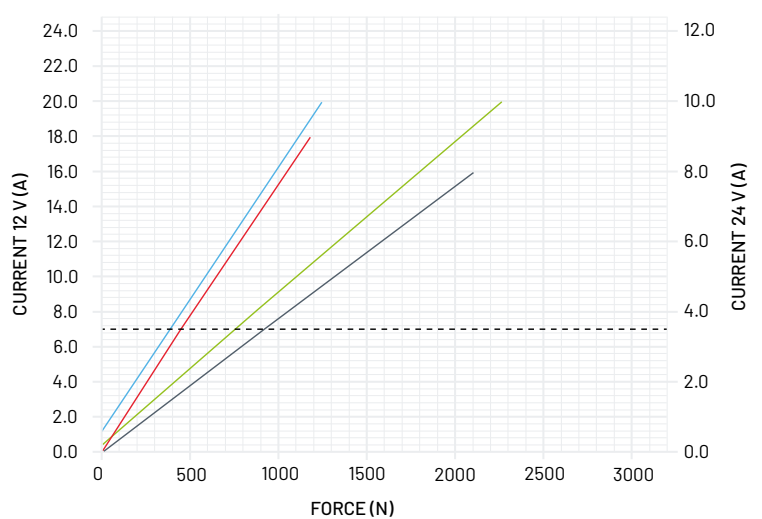

— IPR35-V-12A-XXX-15-65C    — IPR35-V-24A-XXX-15-65C  
— IPR35-V-12A-XXX-8-65C    — IPR35-V-24A-XXX-8-65C

— IPR35-V-12A-XXX-15-65C    — IPR35-V-24A-XXX-8-65C  
— IPR35-V-12A-XXX-8-65C    - - - RATED 3.5 A/7A  
— IPR35-V-24A-XXX-15-65C

Values shown for extension movement



# TECHNICAL DATA

## HORIZONTAL SLIDE

### PERFORMANCE DATA

For horizontal slide [H]

TYPES	Spindle pitch mm/rev	Motor Voltage V DC	No load speed mm/s	Rated		Peak <sup>1</sup>	Holding force	
				force N	speed mm/s	force N	extension N	compression N
IPR35-H-12A-XXX-15-20B	15	12	90	340	70	1,050	180	180
IPR35-H-24A-XXX-15-20B	15	24	90	410	57	950	180	180

<sup>1</sup> Recommended no more than 2 s

### Individual part numbers

TYPES	Stroke / Extended length						
	50 / 361.5 mm	100 / 461.5 mm	150 / 561.5 mm	200 / 661.5 mm	250 / 761.5 mm	300 / 861.5 mm	350 / 961.5 mm
IPR35-H-12A-XXX-15-20B	*	422846	421412	601137	424997	425236	426670
IPR35-H-24A-XXX-15-20B	*	715143	043553	186950	715382	716099	716338

\* Contact Stabilus

### PERFORMANCE DIAGRAMS

Horizontal slide-force/speed ratio

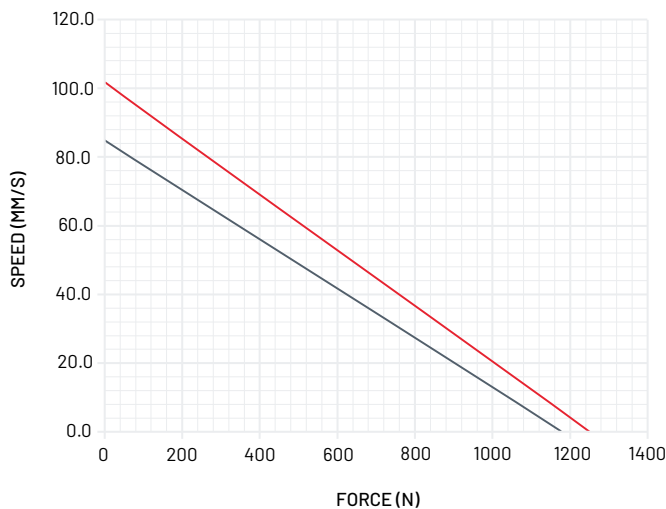

— IPR35-H-12A-XXX-15-20B  
— IPR35-H-24A-XXX-15-20B

Values shown for extension movement

Horizontal slide-force/current ratio

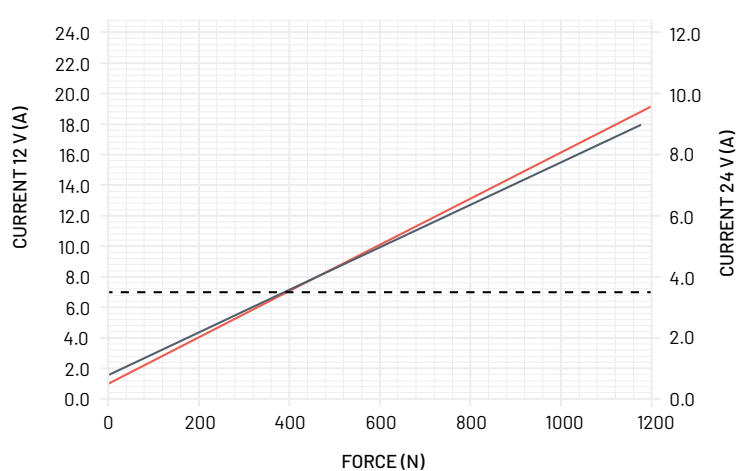

— IPR35-H-12A-XXX-15-20B    - - - RATED 3.5A/7A  
— IPR35-H-24A-XXX-15-20B

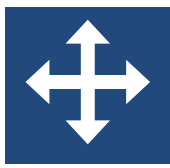

# TECHNICAL DATA

## POSITIONING SYSTEM

### PERFORMANCE DATA

For positioning system [P]

TYPES	Spindle pitch mm/rev	Motor Voltage V DC	No load speed mm/s	Rated		Peak <sup>1</sup>	Holding force	
				force N	speed mm/s	force N	extension N	compression N
IPR35-P-12A-XXX-10-65B	10	12	50	280	46	1,350	550	550
IPR35-P-24A-XXX-10-65B	10	24	50	380	38	1,250	550	550
IPR35-P-12A-XXX-4-65B	4	12	20	630	18	2,550	1,680	1,680
IPR35-P-24A-XXX-4-65B	4	24	20	860	15	2,400	1,680	1,680

<sup>1</sup>Recommended no more than 2 s

### Individual part numbers

TYPES	Stroke / Extended length						
	50 / 361.5 mm	100 / 461.5 mm	150 / 561.5 mm	200 / 661.5 mm	250 / 761.5 mm	300 / 861.5 mm	350 / 961.5 mm
IPR35-P-12A-XXX-10-65B	426909	427148	427865	593967	446268	446507	446746
IPR35-P-24A-XXX-10-65B	713948	703432	703193	548078	714187	714426	714665
IPR35-P-12A-XXX-4-65B	449375	795210	448897	*	*	*	*
IPR35-P-24A-XXX-4-65B	576281	547839	577476	*	*	*	*

\* Contact Stabilus

### PERFORMANCE DIAGRAMS

Positioning system–force/speed ratio

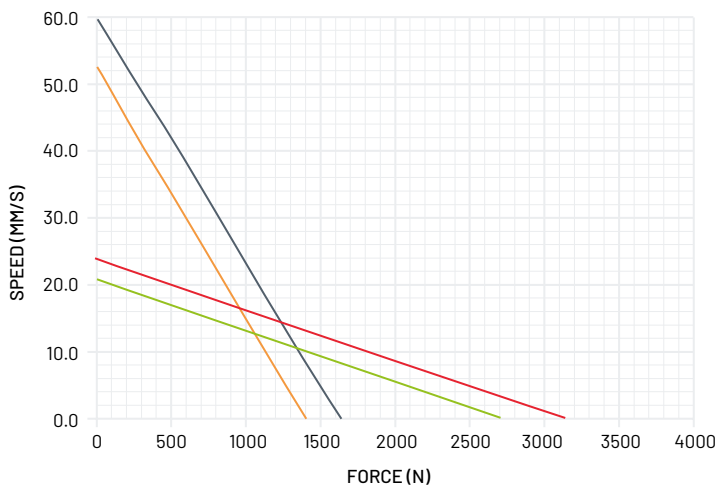

Positioning system–force/current ratio

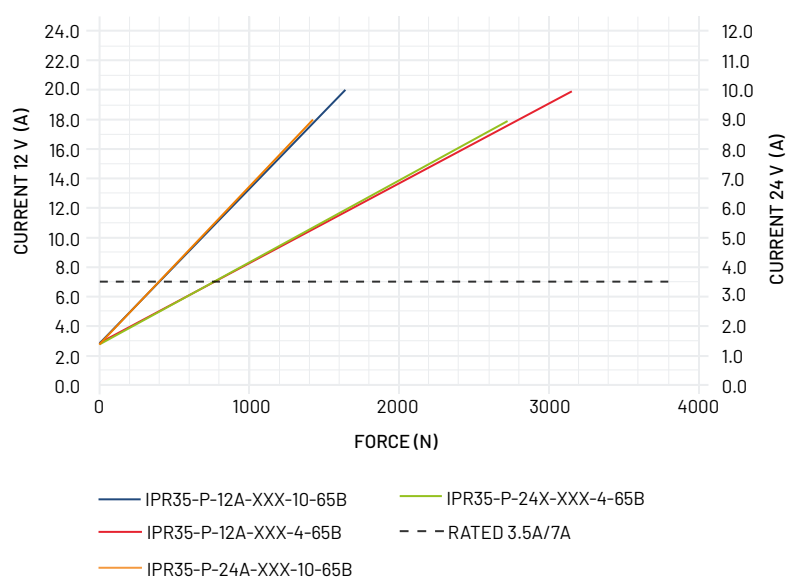

- IPR35-P-12A-XXX-10-65B
- IPR35-P-24A-XXX-10-65B
- IPR35-P-12A-XXX-4-65B
- IPR35-P-24A-XXX-4-65B

- IPR35-P-12A-XXX-10-65B
- IPR35-P-24A-XXX-10-65B
- IPR35-P-12A-XXX-4-65B
- IPR35-P-24A-XXX-4-65B
- - - RATED 3.5A/7A

Values shown for extension movement

# INTERFACES

## MAKE YOUR CONNECTIONS!

### MECHANICAL INTERFACE

#### End fittings

**Type:** 13 mm ball socket with clip

**Orientation:** 360° rotating on spindle tube end, body side fixed orientation

**Mounting static bend:** Requiring height clearance 20 mm on body end

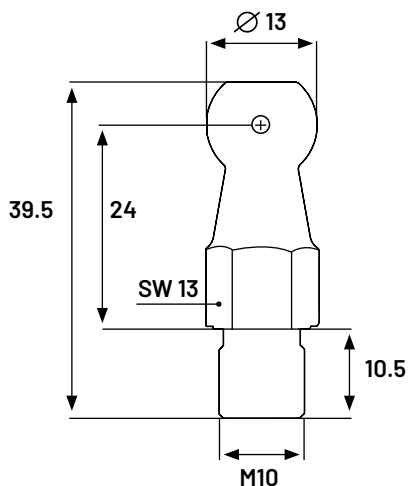
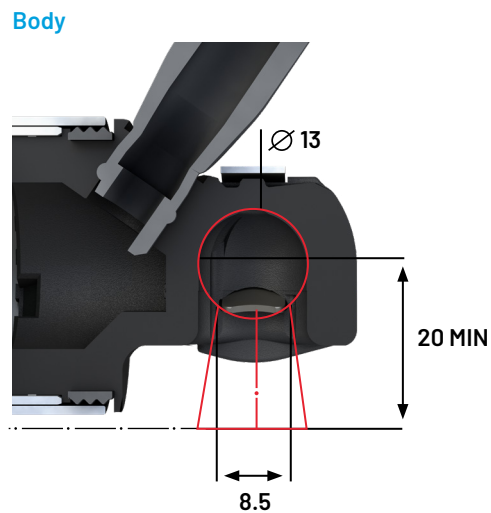
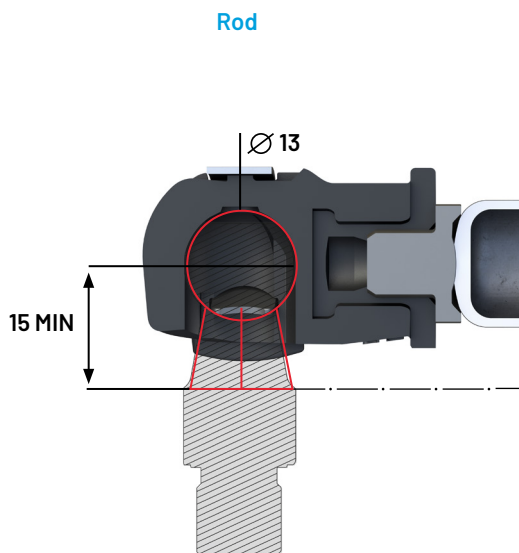

Ball Stud Part Number:  
373597

# INTERFACES

## MAKE YOUR CONNECTIONS!

### ELECTRICAL INTERFACE

#### Technical data

**Hall sensor resolution:** 5 pulses/rev

**Hall sensor supply voltage:** 4 - 24 V

**Motor PWM input:** 8 - 20 kHz

**Connector specification:** Molex Mini-Fit Jr. 6-pin (46992-0610)

#### Polarity assignment

	Plug pin	Polarity
Spindle drive extends	3	+
	6	-

#### Pin assignment

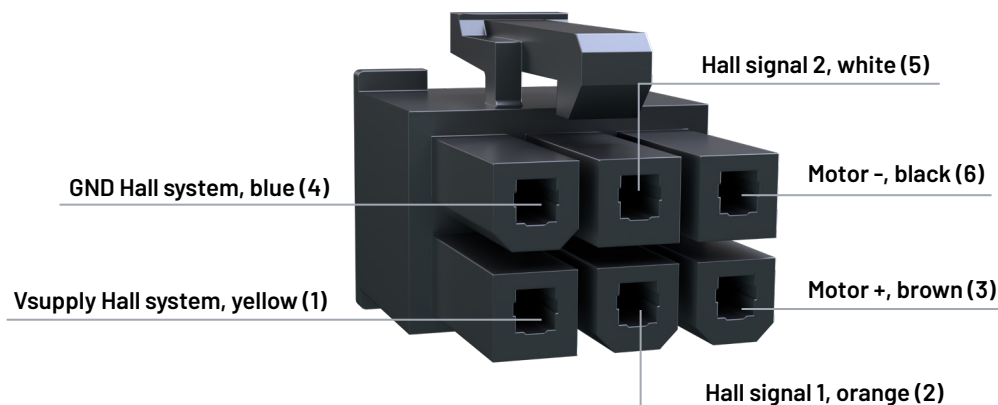

#### Hall sensor system

- Incremental Hall sensors for position and speed control
- Open-drain outputs
- Phase shift between the two signals indicates direction of rotation

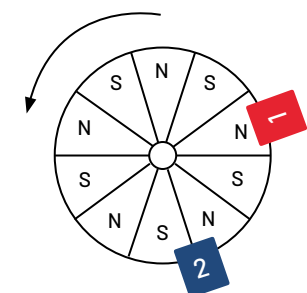

Rotating 10-pole ring magnet

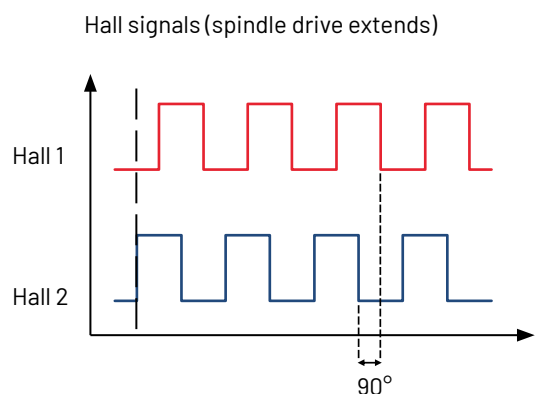

# STABILUS REQUEST FORM

## INDUSTRIAL POWERISE®

Please submit any project requests to [industrial.powerise@stabilus.com](mailto:industrial.powerise@stabilus.com).

### Customer / Project Information

<b>Application Description</b> (Vehicle Name/Model Number, Machine Type, etc.)				
<b>Development phase</b>	Proof of Concept <input type="checkbox"/>	New Design <input type="checkbox"/>	Series changeover <input type="checkbox"/>	Redesign <input type="checkbox"/>
	Other (Please Describe) <input type="checkbox"/>			
<b>Prototyping Schedule</b>	Project Prototype Delivery Date		Quantity of prototype parts	
	Production Release Date	Annual Quantities	Target price per unit / system	
<b>Legal / Certification Requirements / Norms</b>				
<b>Electromagnetic Compatibility requirements (EMC)</b>				

## Application Information

<b>Functional description of the overall system</b>			
<b>Existing version</b>	Manual <input type="checkbox"/>	Pneumatics <input type="checkbox"/>	
	Gas spring <input type="checkbox"/>	Hydraulics <input type="checkbox"/>	
	Electric <input type="checkbox"/>	Other (please describe):	
<b>Supply voltage</b>	12V <input type="checkbox"/>	24V <input type="checkbox"/>	<i>Note:</i> Stabilus can supply a power supply (24V) for Stabilus ECU.
<b>Control System responsibility</b>	Stabilus <input type="checkbox"/>	Customer <input type="checkbox"/>	
<b>Functional requirements of control System</b>			
<b>Manual motion required?</b> Yes <input type="checkbox"/> No <input type="checkbox"/>		<b>Desired force to operate manually</b> _____ kg <input type="checkbox"/> N <input type="checkbox"/>	
<b>Required opening / closing time</b> _____ sec.		<b>Cycle time</b> _____ sec.	
<b>Lifetime / Number of cycles</b> _____			
<b>Operation temperature</b> _____ °C <input type="checkbox"/> °F <input type="checkbox"/>		<b>Storage temperature (if necessary)</b> _____ °C <input type="checkbox"/> °F <input type="checkbox"/>	
<b>Required protection (IP code, etc.)</b>			

## Application Information

### Geometry

Kinematics (data shown in closed position)  
 Example: Flap with 90° opening angle (closed position)

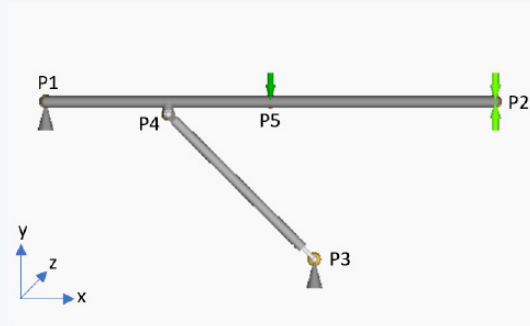

Points can be transferred to multiple other applications

### Type of Application / Category

- Positioning  *high holding forces in extension and compression direction necessary*
- Horizontal adjustment  *low holding forces necessary*
- Vertical adjustment  *high holding force in compression direction necessary*

Point	Description	Coordinate / Value		
P1	Pivot point	x:	y:	z:
P2	Handle point	x:	y:	z:
P3	Fixation point frame	x:	y:	z:
P4	Fixation point flap	x:	y:	z:
P5	COG	x:	y:	z:
	Opening angle [°]			

### Application weight

\_\_\_\_\_ kg

### Unit, please specify:

\_\_\_\_\_

### Additional weights

\_\_\_\_\_ kg

### Unit, please specify:

\_\_\_\_\_

### Use of gas spring as force support possible?

Yes  No

### Use of ball sockets as end-fittings possible?

Yes  No

### 2D drawings / mounting data available?

Yes  No

### 3D CAD models / mounting data available?

Yes  No

### Illustrations of possible applications and market segments

Home-Automation

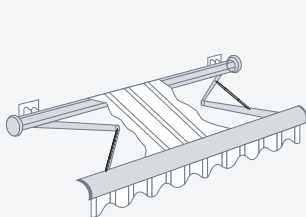

Caravan, Marine, Special Vehicles

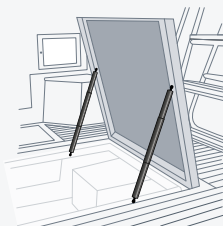

Mechanical engineering

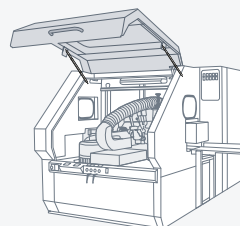

Furniture

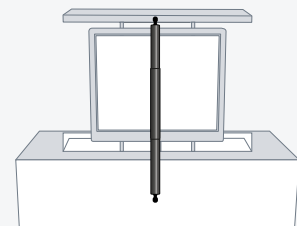

# YOUR COMPLETE SOLUTION FROM A SINGLE SOURCE

The controller has been specifically developed by Stabilus for POWERISE® and is manufactured in Germany. It enables the automatic control of two POWERISE® actuators in parallel. Users benefit from three different operation modes:

- Push-And-Hold = “Jog mode”
- Singel Push (Automatic) = One button press
- Tip-to-Start (open assist) = Initiate by manual movement



## Technical data

Specification	Value	Units	Notes
Operating Voltage	24	V DC	12 V is available for vehicle usage
Number of actuators	2	Actuators	Driven in parallel
Nominal current*	10	Amps	
Dimensions	132 x 91 x 43	[W x L x H] mm	
Ingress protection rating	IP 20		ISO 20653
Connectors	Molex MiniFit Jr		
Input	Normally open contacts		1 input for extension, 1 input for compression, 1 input for end switch

\* Peak current 20 A

## Functions

- Speed control
- Virtual End stop
- Soft Start & Stop
- Allows manual movement

## Protection and safety features

- Overheat
- Voltage & current level
- Misuse – dynamic brake for overspeed
- Obstacle detection
  - Reversing after a collision
  - Overload detection
- Synchronous check (for two actuators)

## Standards

- EN 60335-1:2012 Safety - Household and similar electrical appliances
- EN ISO 13849-1:2023 Safety - Machinery control systems\*
- EN IEC 55014-1:2021 EMC Emission - Household appliances, electric tools and similar apparatus
- EN IEC 55014-2:2021 EMC Immunity - Household appliances, electric tools and similar apparatus
- EN IEC 61000-6-2:2019 EMC Immunity - Industrial environments
- EN IEC 61000-6-3:2021 EMC Emission - Residential environments
- FCC Part 15 B / IECS-003 EMC Emission

\* Depending on the appropriate integration and parametrization of the control unit, it can be used for a performance level up to PLC. For more information, refer to the manual of the control unit



**Industrial POWERISE® Component overview**

Components	Material number
1 Mechanical end-switch	180244
2 Push button	529444
3 Power supply, 230/110 V AC, 24 V DC	285881
4 Mains cable length 1.80 m	DE/EU 913735 UK 651803 US 651564
5 Standard-ECU 24 V	375289
6 Standard-ECU 12 V	210619
7 Powerise Link	374811

Connection cable and further components are available on request

**Powerise Link and Link App**

Powerise Link is a programmable adapter for the control unit. With the Link app, the user can set more than 200 parameters himself.

**Parameterization**

- Closed loop speed control
- Obstacle detection
- Overload detection
- Slam protection
- Acoustic signals
- ...

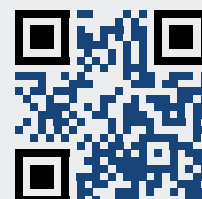

# FROM OUR CATALOG

## FIND THE DATA THAT FIT YOUR APPLICATION

### Performance data

APPLICATION CATEGORY	TYPES	Rated			Peak	Holding
		pushing force N	pulling force N	speed mm/s	force N	force N
Positioning systems	IPR35-P-12A-XXX-10-65B	280	330	46,0	1,350	550
	IPR35-P-24A-XXX-10-65B	380	440	38,0	1,250	550
	IPR35-P-12A-XXX-4-65B	630	740	18,0	2,550	1,680
	IPR35-P-24A-XXX-4-65B	860	980	15,0	2,400	1,680
Horizontal slide	IPR35-H-12A-XXX-15-20B	340	370	70	1,050	180
	IPR35-H-24A-XXX-15-20B	410	440	57	950	180
Vertical lift	IPR35-V-12A-XXX-15-65C	390	210	70	1,100	120 / 390
	IPR35-V-24A-XXX-15-65C	450	280	57	1,050	120 / 390
	IPR35-V-12A-XXX-8-65C	750	420	28	2,000	220 / 760
	IPR35-V-24A-XXX-8-65C	880	550	23	1,900	220 / 760

\* Contact Stabilus

## Individual part numbers

Stroke / Extended length						
50 / 361.5 mm	100 / 461.5 mm	150 / 561.5 mm	200 / 661.5 mm	250 / 761.5 mm	300 / 861.5 mm	350 / 961.5 mm
426909	427148	427865	593967	446268	446507	446746
713948	703432	703193	548078	714187	714426	714665
449375	795210	448,897	*	*	*	*
576281	547839	577476	*	*	*	*
*	422846	421412	601137	424997	425236	426670
*	715143	043553	186950	715382	716099	716338
709410	709171	425953	602332	425714	425475	426192
706064	705347	720162	187189	720401	720640	720879
709649	709888	372895	606156	372417	373612	374807
706303	705825	921160	188384	721357	721596	721118

# INDUSTRIAL POWERISE®

## YOUR APPLICATION – YOUR DRIVE



### VERTICAL LIFT TAILGATES AND HOODS

**Perfect for tailgates, hoods, and linear adjustments in a vertical direction:**

- Various spindle pitches for a multitude of applications
- A combination with gas springs relieves strain on the drive and allows:
  - Higher weights
  - Ergonomic manual movement
  - Higher travel speeds
- Optimal design for mechanical friction brakes for these applications:
  - Only effective in the direction of movement
  - Keep the application open after the end of movement



### HORIZONTAL SLIDE DOORS & GATES

**Only slight braking effect in both directions, for example to be able to move doors and gates smoothly by hand:**

- High travel speed
- Easy manual adjustment setting
- Simple and continuous positioning



# YOUR MOTION. OUR SOLUTION.

## STABILUS

## THE GLOBAL MOTION CONTROL SOLUTION PROVIDER TO THE INDUSTRY

- Specialized industrial brands with unique solutions and expertise for each market.
- Wide product range – from simple to complex requirements across all industries.
- Broad global presence that closely connects us with all markets.



### Stabilus group of industrial brands

**STABILUS**

Globally leading series gas spring manufacturer meeting highest automotive quality standards for industrial products in all plants.



**ACE**  
A STABILUS COMPANY

Expert in **industrial damping** and deceleration with **excellent customer support** satisfying most demanding application requirements.



**CULTRARO**  
A STABILUS COMPANY

Global specialists in the **design and manufacture of dampers in compact sizes with high torques** and forces, offering rotary, axial and linear solutions for every damping need.



**DESTACO**  
A STABILUS COMPANY

A global leader in the design and manufacture of **high-performance automation, workholding, and remote handling solutions.**



**FABREEKA**  
A STABILUS COMPANY

Leading supplier for **individual vibration isolation and shock control** solutions.



**General Aerospace**  
A STABILUS COMPANY

Innovative supplier of distinctive **airline motion control solutions.**



**HAHN GAS FEDERN**  
A STABILUS COMPANY

Experienced provider of **customized and special gas springs** with **very fast time to market.**



**TECHPRODUCTS**  
A STABILUS COMPANY

Experienced manufacturer of **elastomeric vibration isolators and shock mounts.**

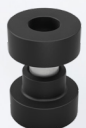

## Stabilus GmbH

Wallersheimer Weg 100

56070 Koblenz

Germany

T +49 261 - 8900-0

info@stabilus.com

[www.stabilus.com](http://www.stabilus.com)

QR code takes you to our  
International Locations

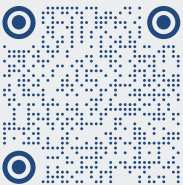

**in** @stabilus

**f** @stabilusgroup